

- Ben
DPA 4060
- Sophie
DPA 4060
- Chloe
DPA 4060
- Ryan
DPA 4060
- Zoey
DPA 4060
- Janette
DPA 4060
- Brianna
DPA 4060
- Jayden
DPA 4060
- Greg
DPA 4060
- Spare 1
DPA 4060
- Spare 2
DPA 4060

ULXD4Q #1

| |
|-----------------|
| 500.500 (TBD) |
| 500.500 (TBD) |
| 500.500 (TBD) |
| 500.500 (TBD) |
| Dante Primary |
| Dante Secondary |

ULXD4Q #2

| |
|-----------------|
| 500.500 (TBD) |
| 500.500 (TBD) |
| 500.500 (TBD) |
| 500.500 (TBD) |
| Dante Primary |
| Dante Secondary |

ULXD4Q #3

| |
|-----------------|
| 500.500 (TBD) |
| 500.500 (TBD) |
| 500.500 (TBD) |
| 500.500 (TBD) |
| Dante Primary |
| Dante Secondary |

Cisco SG300-24 Primary

| |
|---------|
| Port 1 |
| Port 2 |
| Port 3 |
| Port 4 |
| Port 5 |
| Port 6 |
| Port 7 |
| Port 8 |
| Port 9 |
| Port 10 |

Cisco SG300-24 Secondary

| |
|---------|
| Port 1 |
| Port 2 |
| Port 3 |
| Port 4 |
| Port 5 |
| Port 6 |
| Port 7 |
| Port 8 |
| Port 9 |
| Port 10 |

A2 Mac Mini

Ethernet
USB-C

QLab Mac Mini

Ethernet
USB-C

Cisco SG300-10 Primary

| |
|---------|
| Port 1 |
| Port 2 |
| Port 3 |
| Port 4 |
| Port 5 |
| Port 6 |
| Port 7 |
| Port 8 |
| Port 9 |
| Port 10 |

Cisco SG300-10 Secondary

| |
|---------|
| Port 1 |
| Port 2 |
| Port 3 |
| Port 4 |
| Port 5 |
| Port 6 |
| Port 7 |
| Port 8 |
| Port 9 |
| Port 10 |

God Mic Shure 565SD

XLR

Yamaha CL3

| | |
|-----------------|-------------|
| Dante Primary | |
| Dante Secondary | |
| Omni In 1 | Omni Out 1 |
| Omni In 2 | Omni Out 2 |
| Omni In 3 | Omni Out 3 |
| Omni In 4 | Omni Out 4 |
| Omni In 5 | Omni Out 5 |
| Omni In 6 | Omni Out 6 |
| Omni In 7 | Omni Out 7 |
| Omni In 8 | Omni Out 8 |
| Omni In 9 | Omni Out 9 |
| Omni In 10 | Omni Out 10 |
| Midi In | Midi Out |
| Control | |

d&b DS10 #1 Network Bridge

| | |
|-----------------|-----------|
| Dante Primary | AES 1/2 |
| Dante Secondary | AES 3/4 |
| | AES 5/6 |
| | AES 7/8 |
| | AES 9/10 |
| | AES 11/12 |
| | AES 13/14 |
| | AES 15/16 |

d&b DS10 #2 Network Bridge

| | |
|-----------------|-----------|
| Dante Primary | AES 1/2 |
| Dante Secondary | AES 3/4 |
| | AES 5/6 |
| | AES 7/8 |
| | AES 9/10 |
| | AES 11/12 |
| | AES 13/14 |
| | AES 15/16 |

Note: All connections between DS10 and D20 amplifiers are AES.

d&b D20 #7 Amplifier

| | |
|------------|--------------|
| AES in 1/2 | A - Rear HL |
| AES in 3/4 | B - Rear HR |
| | C - HR Cat 1 |
| | D - HR Cat 2 |

d&b D20 #1 Amplifier

| | |
|------------|--------------|
| AES in 1/2 | A - Main L |
| AES in 3/4 | B - Main R |
| | C - Vocal C |
| | D - Screen C |

d&b D20 #2 Amplifier

| | |
|------------|------------------|
| AES in 1/2 | A - |
| AES in 3/4 | B - |
| | C - Front Surr L |
| | D - Front Surr R |

d&b D20 #3 Amplifier

| | |
|------------|-----------------|
| AES in 1/2 | A - Mid Surr L |
| AES in 3/4 | B - Mid Surr R |
| | C - Rear Surr L |
| | D - Rear Surr R |

d&b D20 #5 Amplifier

| | |
|------------|--------------|
| AES in 1/2 | A - HR Cat 3 |
| AES in 3/4 | B - HL Cat 1 |
| | C - HL Cat 2 |
| | D - HL Cat 3 |

d&b D20 #6 Amplifier

| | |
|------------|----------------|
| AES in 1/2 | A - HL SUB |
| AES in 3/4 | B - HR SUB |
| | C - Upstage FX |
| | D - SR FX |

Note: All connections between D20 and speakers are NL2

- Rear HL d&b E4
- Rear HR d&b E4
- HR Cat 1 d&b E4
- HR Cat 2 d&b E4
- Music Left d&b E12-D
- Music Right d&b E12-D
- Vocal Center d&b E12-D
- Screen C d&b Y7P
- Front Surround L d&b T10
- Front Surround R d&b T10
- Mid Surround L d&b T10
- Mid Surround R d&b T10
- Rear Surround L d&b T10
- Rear Surround R d&b T10
- HR Cat 3 d&b E4
- HL Cat 1 d&b E4
- HL Cat 2 d&b E4
- HL Cat 3 d&b E4
- HL SUB d&b B6
- HR SUB d&b B6
- Upstage FX d&b E8
- SR FX d&b E8

to House System House 70V



The Burials Signal Line Diagram

Cohen Family Studio Theater

| | |
|------------------------------|-----------------|
| Dr. By: Patrick John Kiernan | Date: 3/22/2022 |
| Dir: Richard Hess | |
| Des: Patrick John Kiernan | Rev: 4/13/2022 |

1 of 3

Notes: Drawing not to scale. Verify with installer.

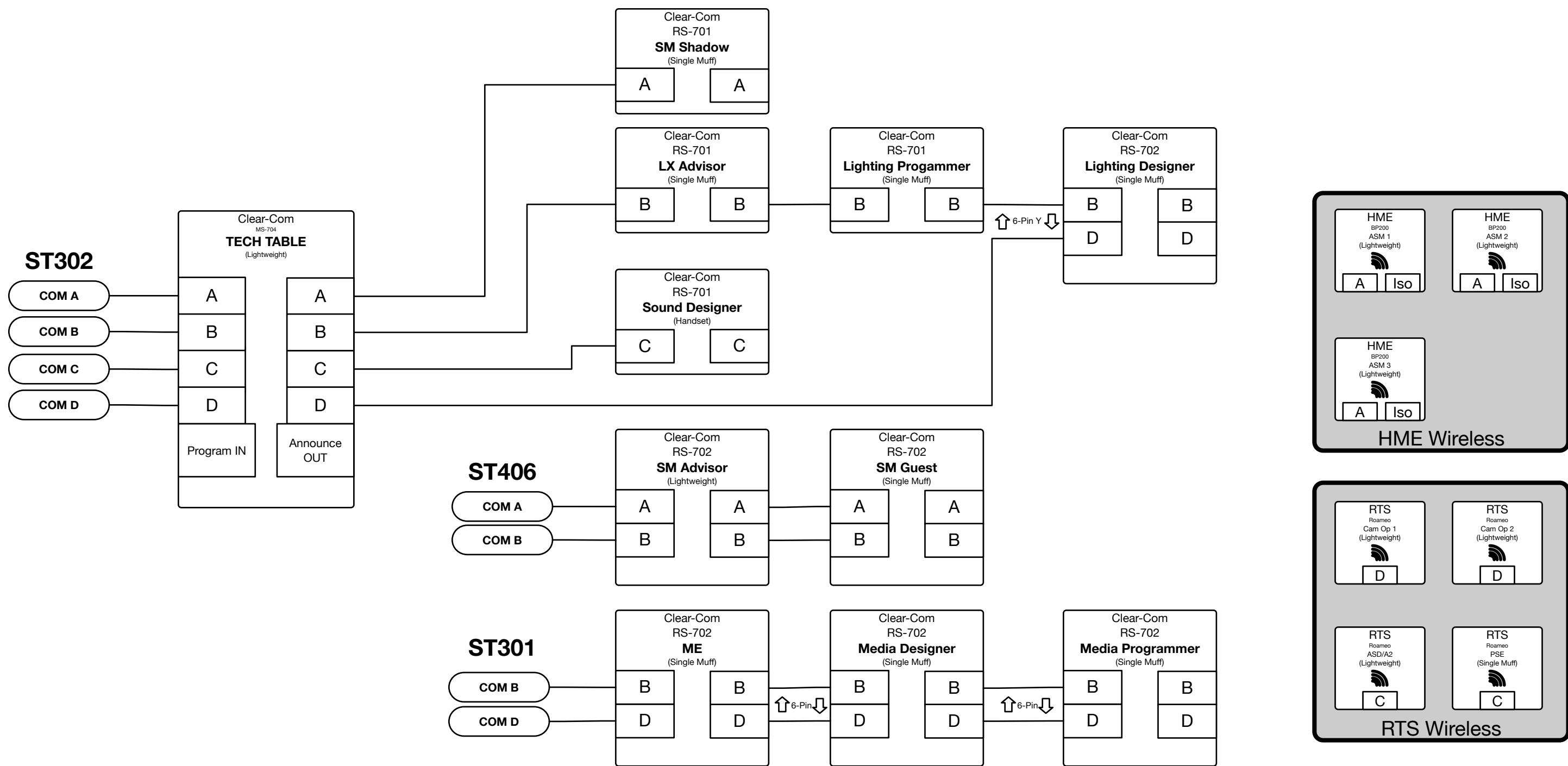

| | | |
|--|--|-----------------|
| | The Burials Signal Line Diagram | |
| | Cohen Family Studio Theater | |
| | Dr. By: Patrick John Kiernan | Date: 3/22/2022 |
| | Dir: Richard Hess | |
| | Des: Patrick John Kiernan | Rev: 4/13/2022 |
| | 2 of 3 | |
| Notes: Except where noted, all cabling is XLR. | | |

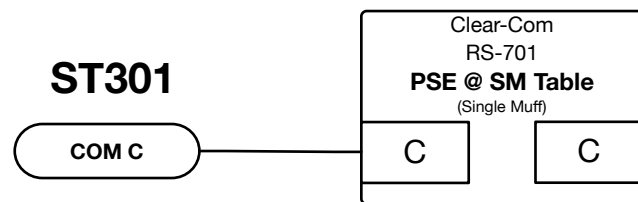

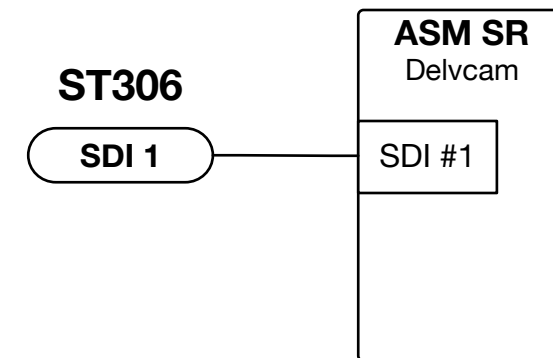
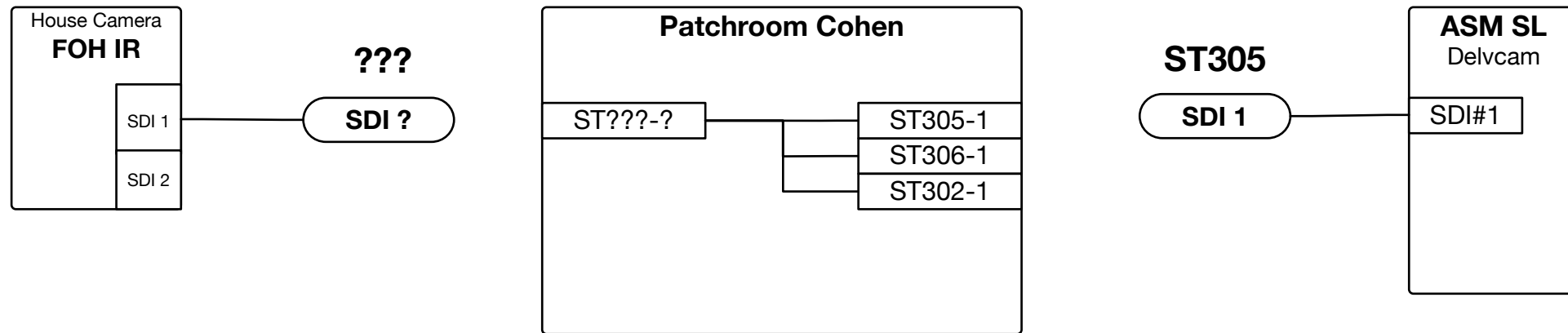

| | | |
|---------------|---|-----------------|
| | The Burials Signal Line Diagram | |
| | Cohen Family Studio Theater | |
| | Dr. By: Patrick John Kiernan | Date: 3/22/2022 |
| | Dir: Richard Hess | |
| | Des: Patrick John Kiernan | Rev: 4/13/2022 |
| | Notes: Drawing not to scale. Verify with installer. | |
| 3 of 3 | | |